



2017 UPA Pro Farm Rules 9500lb & 10000lb

1. The 9,500 lb. class will be limited to a maximum of 466 cubic inch displacement plus 1% tolerance.
2. The 10,000 lb. class will be limited to a maximum of 650 cubic inch displacement plus 1% tolerance.
3. Replacement blocks are allowed provided they bolt to the original factory cast clutch bell housing without any modification or use of adapter plates. Head will be the same manufacturer as crankcase. No aftermarket heads allowed.
4. A maximum RPM of 3500 will be allowed.
5. A "P" series injection pump up to model 7100 with 13mm plungers will be allowed. No 8000 series allowed.
6. OEM exhaust and intake manifolds only. Modified inlets of the intakes are allowed.
7. Tractors are limited to one turbocharger with small exhaust mounting base and maximum inducer of 3 inches. Map Groove Width of .250 max.
8. Exhaust pipe must have two 3/8 inch bolts in the vertical portion of the exhaust pipe. Bolts must be installed 90 degrees to each other and within one inch of each other. No rain caps or curved pipes allowed.
9. All tractors will have a steel flywheel and clutch assembly. You must fill out and turn in to an officer a clutch certifying form if you have not already done so.
10. An approved scatter blanket that is in good condition and covers the full clutch area will be required.
11. Homemade front ends are allowed. They will be subject to approval of the UPA board.
12. All tractors will have a dead man's throttle.
13. All tractors will have electric fans.
14. Tractors will have OEM style hoods and fenders. Fenders must cover a portion of the top of the tire.
15. Tractors must be equipped with minimum of one 2 1/2 lb. dry chemical or halon fire extinguisher. Fire extinguisher must have working gauge, be fully charged, and in working condition. Fire extinguisher must be mounted convenient to operator.
16. If a fiberglass or aluminum hood is used a metal shield around the turbo (minimum of .060) will be required.
17. Wheel base shall not exceed 114 inches. A maximum of 13 feet from center of rear axle to front part of weights, excluding front hitch, is allowed.

18. All tractors will have welded axle plates. Dual hubs will not be allowed.
19. All tractors will have side shields. Inner side shields are recommended.
20. All tractors must either run safety tie bars mounted to rear axle housing with at least four axle housing bolts and extending forward to flywheel area and fastened to side of block or main frame with at least two 5/8 inch bolts, or a one piece frame extending from front of tractor to rear axle housing mounting bolts. Tie bars or frame must be sufficient strength to support weight of tractor with the bolts removed.
21. All tractors will have a balancer retainer.
22. A SFI cage is recommended. If a short ROPS is used an approved helmet is required. If a cage is used a full fire suit, including coat, pants, shoes, gloves, and full face helmet is required.
23. All tractors will have wheelie bars capable of supporting the tractor's weight when jacked up .SEE DIAGRAM FOR SPECIFICATIONS.
24. A maximum tire size of 18.4 x 42 or 20.8 x 38 on any width rim. Any style cut on the tires will be allowed.
25. Hook point is to be a minimum of 18 inches behind center of rear axle and a maximum of 20 inches in height to be rigid in all directions. Hitching eye to be a minimum of one (1) inch in thickness with a 3 X 3 1/2 inch inside diameter hole.
26. Water injection will be allowed. Pump lubrication is the only legal additive allowed. A Tee Fitting in the supply line from the water tank, with a valve for ease of access to the water supply, will be required for testing. If test results show an illegal substance is present it will result in disqualification for a year to date.
27. No intercoolers or cool boxes allowed.
28. Any contestant wishing to pull a tractor with a cool box must have them fully disabled in order to compete. They will be subject to inspection by an official at any time.
29. Membership dues are \$80 for the vehicle and \$40 per driver. At the first event, before hooking, you will be required to pay membership dues. There will be a \$25 late fee per member if paid after first pull. Non-member pullers with a legal vehicle will be allowed to purchase a 1-day membership for a fee of \$25, per event, per vehicle with a limit of 2 events. 1-day members will not be eligible for points. Points will not be started until full membership is paid.

Diagram for Rule #23

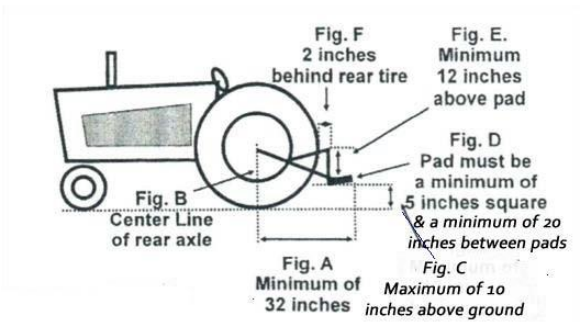

NOTE: The stabilizer bar system must be able to support the weight of the machine in the heaviest class pulled. Jacking up the pads so the machine is completely off the ground will be a good test.

UPA 2017 CC- 12-2-16